



Thomson 60 Case® Quick Shaft

“Quick shaft” is precut and packaged stock length shafting in popular:

- Inch and metric sizes
- L tolerance class and MM tolerance class
- Materials (carbon steel, 440C stainless steel, lightweight 52100 tubular)
- Standard options (predrilled and chrome-plated plain ends)



Thomson 60 Case quick shaft can be easily stocked by authorized Thomson distributors or end users.

You may want to have a few pieces of Thomson quick shaft in your stock room if you are not sure of the exact length you may need for that potential third-shift breakdown or you perform your own special machining of various lengths and do not want to carry different cut-to-length sizes.

All Thomson quick shaft shafting are oil preserved and placed in a VCI bag for long-term storage and labeled for your convenience.

Part Number Description

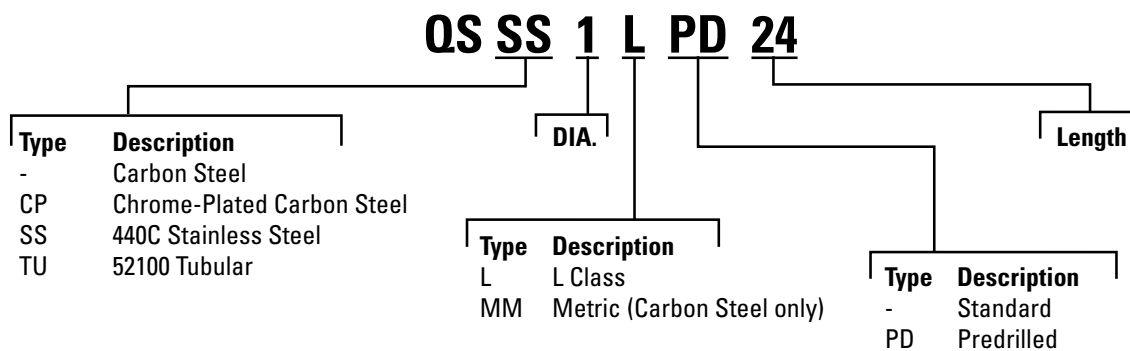

Not all options are available in all sizes.
 See catalog pages or contact Thomson Customer Support for combination availability.
 For additional information on material options, see page 264.

Thomson RoundRail Linear Guides and Components

60 Case Quick Shaft

Carbon Steel - Inch

Hardness: 60 ROCKWELL C Min.

Surface Finish: 8 Ra microinch Max

Roundness: .000080"

Straightness: .001" Per Foot Cumulative

Taper: .0001"

Part Number	Stock Lengths (in)	Diameter Tolerance (in)	Min. Hardness Depth (in)	Weight Per Inch (lb)
QS 1/4 L	6, 9, 12, 15, 18, 24, 30, 36, 42, 48, 60	.2495	.027	.014
		.2490		
QS 3/8 L	6, 12, 18, 24, 30, 36, 48, 60	.3745	.027	.031
		.3740		
QS 1/2 L	6, 9, 12, 15, 18, 24, 30, 36, 42, 48, 54, 60	.4995	.040	.055
		.4990		
QS 5/8 L	12, 15, 18, 24, 30, 36, 42, 48, 54, 60	.6245	.040	.086
		.6240		
QS 3/4 L	12, 15, 18, 24, 30, 36, 42, 48, 60, 66, 72	.7495	.060	.125
		.7490		
QS 1 L	12, 18, 24, 30, 36, 42, 48, 60, 66, 72	.9995	.080	.222
		.9990		
QS 1 1/4 L	12, 18, 24, 30, 36, 42, 48, 54, 60, 72	1.2495	.080	.348
		1.2490		
QS 1 1/2 L	12, 18, 24, 30, 36, 42, 48, 54, 60, 66, 72	1.4994	.080	.500
		1.4989		
QS 1 3/4 L	12, 18, 24, 30, 36, 42, 48, 60, 72	1.7495	.100	.681
		1.7490		
QS 2 L	12, 18, 24, 30, 36, 42, 48, 60, 72	1.9994	.100	.890
		1.9987		

Carbon Steel - Metric

Hardness: 60 ROCKWELL C Min.

Surface Finish: 8 Ra microinch Max

Roundness: .000080"

Straightness: .001" Per Foot Cumulative

Taper: .0001"

Part Number	Stock Lengths (mm)	Diameter		Min. Hardness Depth		Weight Per m	Weight Per inch
		(mm)	(in)	(mm)	(in)	(kg)	(lb)
QS 10 MM	500,1000	10.00	.3937	.069	.027	0.63	.035
		9.99	.3932				
		12.00	.4724				
QS 12 MM	250, 500, 750, 1000, 1200, 1500, 2000	11.99	.4720	1.02	.040	0.89	.05
		16.00	.6299				
QS 16 MM	250, 500, 750, 1000, 1200, 1500, 2000	15.99	.6295	1.02	.040	1.57	.088
		20.00	.7874				
QS 20 MM	250, 500, 750, 1000, 1200, 1500, 2000	19.99	.7869	1.52	.060	2.33	.13
		25.00	.9843				
QS 25 MM	500, 750, 1000, 1200, 1500, 2000	24.99	.9838	2.03	.080	3.87	.216
		30.00	1.1811				
QS 30 MM	500, 750, 1000, 1500, 2000	29.99	1.1806	2.03	.080	5.57	.311
		40.00	1.5748				
QS 40 MM	500, 750, 1000, 1500, 2000	39.99	1.5743	2.03	.080	9.90	.553



440C Stainless Steel - Inch

Hardness: 50 ROCKWELL C Min.

Surface Finish: 8 Ra microinch Max

Roundness: .000080"

Straightness: .001" Per Foot Cumulative

Taper: .0001"

Part Number	Stock Lengths (in)	Diameter Tolerance (in)	Min. Hardness Depth (in)	Weight Per Inch (lb)
QSSS 1/4 L	6, 12, 18, 24, 30, 36, 48, 60	.2495	.027	.014
		.2490		
QSSS 3/8 L	6, 12, 18, 24, 30, 36, 48, 60	.3745	.027	.031
		.3740		
QSSS 1/2 L	12, 18, 24, 30, 36, 42, 48, 54, 60	.4995	.040	.055
		.4990		
QSSS 5/8 L	12, 18, 24, 30, 36, 42, 48, 54, 60	.6245	.040	.086
		.6240		
QSSS 3/4 L	12, 18, 24, 30, 36, 42, 48, 54, 60, 66, 72	.7495	.060	.125
		.7490		
QSSS 1 L	18, 24, 30, 36, 42, 48, 54, 60, 66, 72	.9995	.080	.222
		.9990		
QSSS 1 1/4 L	12, 18, 24, 30, 36, 42, 48, 54, 60, 72	1.2495	.080	.348
		1.2490		
QSSS 1 1/2 L	18, 24, 30, 36, 42, 48, 54, 60, 66, 72	1.4994	.080	.500
		1.4989		

52100 Tubular - Inch

Hardness: 58 ROCKWELL C Min.

Surface Finish: 8 Ra microinch Max

Roundness: .000080"

Straightness: .001" Per Foot Cumulative

Taper: .0001"

Part Number	Stock Lengths (in)	Nominal I.D. (in)	Diameter Tolerance (in)	Min. Hardness Depth (in)	Weight Per Inch (lb/in)
QSTU 1 L	12, 18, 24, 48, 60	.599 ± 5%	.9995	.080	.158
			.9990		
QSTU 1 1/2 L	12, 18, 24, 48, 60	.890 ± 5%	1.4994	.080	.328
			1.4989		
QSTU 2 L	12, 24, 48, 60	1.250 ± 5%	1.9994	.100	.542
			1.9987		

Thomson RoundRail Linear Guides and Components

Carbon Steel Predrilled - Inch

Hardness: 60 ROCKWELL C Min.
 Surface Finish: 8 Ra microinch Max
 Roundness: .000080"
 Straightness: .001" Per Foot Cumulative
 Taper: .0001"
 Y1 = Y2 Standard

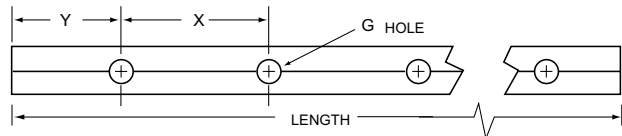

Part Number	Stock Lengths (in)	Diameter Tolerance (in)	X (in)	G Thread Size	Min. Hardness Depth (in)	Weight Per Inch (lb)
QS 1/2 L PD	12, 18, 24, 30, 36, 42, 48, 54, 60, 72	.4995	4	#6-32	.040	.055
		.4990				
QS 5/8 L PD	12, 18, 24, 30, 36, 42, 48, 54, 60, 72	.6245	4	#8-32	.040	.086
		.6240				
QS 3/4 L PD	12, 18, 24, 30, 36, 42, 48, 54, 60, 72	.7490	6	#10-32	.060	.125
		.7485				
QS 1 L PD	18, 24, 30, 36, 42, 48, 54, 60, 72	.9995	6	1/4-20	.080	.222
		.9990				
QS 1 1/4 L PD	18, 24, 30, 36, 42, 48, 54, 60, 72	1.2490	6	5/16-18	.080	.348
		1.2485				
QS 1 1/2 L PD	18, 24, 30, 36, 42, 48, 54, 60, 72	1.4994	8	3/8-16	.080	.500
		1.4989				

440C Stainless Steel Predrilled - Inch

Hardness: 50 ROCKWELL C Min.
 Surface Finish: 8 Ra microinch Max
 Roundness: .000080"

Straightness: .001" Per Foot Cumulative
 Taper: .0001"
 Y1 = Y2 Standard

Part Number	Stock Lengths (in)	Diameter Tolerance (in)	X (in)	G Thread Size	Min. Hardness Depth (in)	Weight Per Inch (lb)
QSSS 1/2 L PD	24, 30, 36, 42, 48, 60, 72	.4995	4	#6-32	.040	.055
		.4990				
QSSS 5/8 L PD	24, 30, 36, 42, 48, 54, 60, 72	.6245	4	#8-32	.040	.086
		.6240				
QSSS 3/4 L PD	24, 30, 36, 42, 48, 54, 60, 72	.7490	6	#10-32	.060	.125
		.7485				
QSSS 1 L PD	18, 24, 30, 36, 42, 48, 54, 60, 72	.9995	6	1/4-20	.080	.222
		.9990				
QSSS 1 1/4 L PD	18, 24, 30, 36, 42, 48, 54, 60, 72	1.2490	6	5/16-18	.080	.348
		1.2485				
QSSS 1 1/2 L PD	18, 24, 30, 36, 42, 48, 54, 60, 72	1.4994	8	3/8-16	.080	.500
		1.4989				

Chrome Plated Plain Ends - Inch

Hardness: 60 ROCKWELL C Min.
 Surface Finish: 8 Ra microinch Max
 Roundness: .000080"

Straightness: .001" Per Foot Cumulative
 Taper: .0001"

Part Number	Stock Lengths (in)	Diameter Tolerance (in)	Min. Hardness Depth (in)	Weight Per Inch (lb)
QSCP 1/2 L	6, 12, 18, 24, 30, 36, 42, 48, 60	.4995	.040	.055
		.4990		
QSCP 5/8 L	12, 18, 24, 30, 36, 42, 48, 54, 60	.6245	.040	.086
		.6240		
QSCP 3/4 L	12, 18, 24, 30, 36, 42, 48, 54, 60	.7595	.060	.125
		.7490		
QSCP 1 L	12, 18, 24, 30, 36, 42, 48, 54, 60, 72	.9995	.080	.222
		.9990		
QSCP 1 1/4 L	18, 24, 30, 36, 42, 48, 54, 60, 66, 72	1.2495	.080	.348
		1.2490		
QSCP 1 1/2 L	18, 24, 30, 36, 42, 48, 54, 60, 66, 72	1.4994	.080	.500
		1.4989		